



High Torque Motor

Peak power 160Nm/28KW without gear, up to 4300rpm, 18kg only!

What are advantages of axial flux motor?

High torque density: Axial flux motors have a higher torque density than radial flux motors, which means they can deliver more torque per unit of volume. This makes them ideal for applications like electric motorcycles, electric go-kart, electric boats.

High efficiency: Axial flux motors have a high efficiency, which means they can convert a higher percentage of electrical energy into mechanical energy. This results in lower energy losses and longer battery life in electric vehicles.

Field weakening capability: The motor is designed to handle the high-speed operation, allows the motor to operate at speeds 60% higher than its base (or rated) speed without requiring a higher input voltage. The field weakening control offers the advantage of higher speed operation and greater flexibility in applications with variable speed requirements.

Compact size and low weight: Axial flux motors are more compact and lightweight than radial flux motors of similar power output. This makes them suitable for applications where weight and size are critical, such as drones and robots.

Regenerative Braking Capability: Like other BLDC/PMSM motors, axial flux motors can efficiently support regenerative braking, which is particularly useful in electric vehicle applications.

Reduced Noise and Vibration: The design of axial flux motors often results in quieter operation and less vibration compared to traditional radial motors, which is a significant advantage in noise-sensitive applications.

Less Cogging Torque: The unique design of axial flux motors can result in lower cogging torque. This is beneficial in applications where smooth operation and precise control are necessary.





HTM07KW Splined Shaft

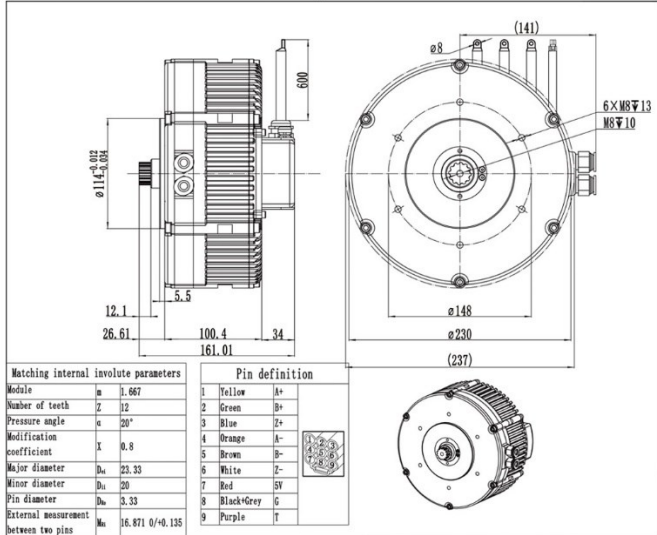

HTM07KW Standard Shaft (key slot)

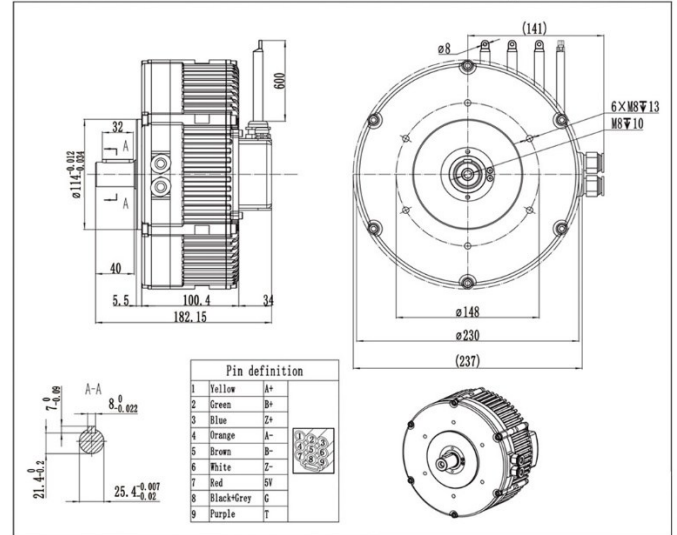

HTM11KW Splined Shaft

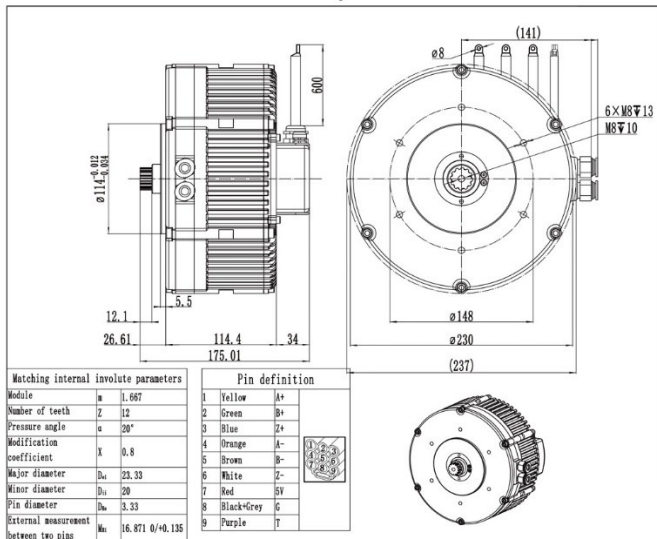

HTM11KW Standard Shaft (key slot)

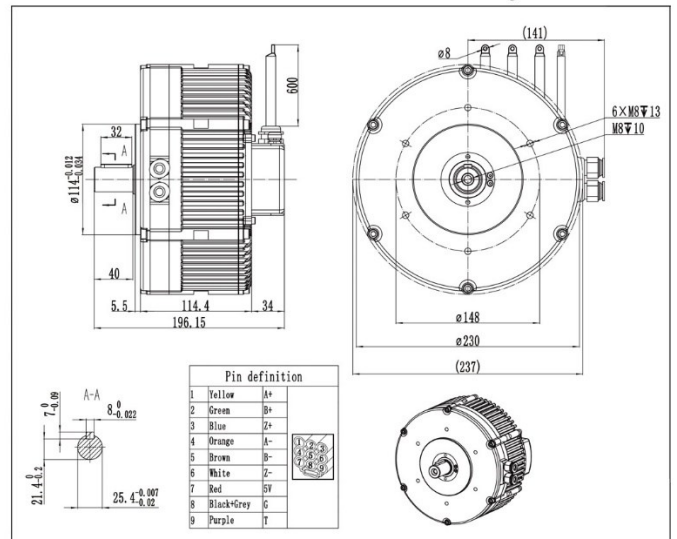

HTM07KW & HTM11KW MAIN PARAMETERS

	HTM07KW	HTM11KW		HTM07KW	HTM11KW
Rated Power(kW)	7	11	Peak Torque(N.m)	110	160
Peak Power(kW)	18	28	Interphase Resistance(mΩ)	18.6	6.7
Rated Voltage(V)	72	72	Duty	S5	S5
Rated Current(A)	92	170	Number of Pole-Pairs	5	5
Max. Phase Current(A)	400	800	Insulation Grade	H	H
Max. Current Duration(s)	30	30	IP Rating	IP65	IP65
Rated Speed(rpm)	1950	2500	Cooling Type	Natural cooling	Natural cooling
Max Speed(rpm)	3800	4300	Net Weight(kg)	15	18
Rated Torque(N.m)	45	60			